

**NOTES:**

- WEIGHTS ARE APPROXIMATE WITH (2) ELEMENTS
- THIS EQUIPMENT SHALL BE SUPPORTED SUCH THAT NO MOMENTS OR FORCES ARE ON THE INLET AND OUTLET FLANGES

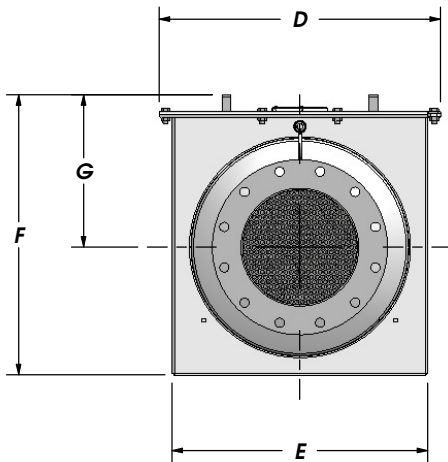

MODEL	WEIGHT (lbs.)	A (in.)	B (in.)	C (in.)	D (in.)	E (in.)	F (in.)	G (in.)
EC-0800-02-S-XX	109	2' - 150#	2' - 150#	33.250	15.082	12.019	15.154	9.144
EC-0800-03-S-XX	113	3' - 150#	3' - 150#	33.250	15.082	12.019	15.154	9.144
EC-1000-02-S-XX	127	2' - 150#	2' - 150#	33.250	17.082	14.019	17.154	10.144
EC-1000-03-S-XX	131	3' - 150#	3' - 150#	33.250	17.082	14.019	17.154	10.144
EC-1200-03-S-XX	156	3' - 150#	3' - 150#	36.250	19.082	16.019	19.154	11.144
EC-1200-04-S-XX	161	4' - 150#	4' - 150#	36.250	19.082	16.019	19.154	11.144
EC-1200-05-S-XX	162	5' - 150#	5' - 150#	36.250	19.082	16.019	19.154	11.144
EC-1450-05-S-XX	200	5' - 150#	5' - 150#	36.250	21.582	18.519	22.404	13.144
EC-1450-06-S-XX	203	6' - 150#	6' - 150#	36.250	21.582	18.519	22.404	13.144
EC-1450-08-S-XX	203	8' - 150#	8' - 150#	36.250	21.582	18.519	22.404	13.144
EC-1950-06-S-XX	280	6' - 150#	6' - 150#	44.875	26.582	23.519	26.904	15.144
EC-1950-08-S-XX	280	8' - 150#	8' - 150#	44.875	26.582	23.519	26.904	15.144
EC-1950-10-S-XX	294	10' - 150#	10' - 150#	44.875	26.582	23.519	26.904	15.144
EC-2150-10-S-XX	373	10' - 150#	10' - 150#	44.875	28.688	25.625	29.063	16.250
EC-2150-12-S-XX	391	12' - 150#	12' - 150#	44.875	28.688	25.625	29.063	16.250
EC-2150-14-S-XX	400	14' - 150#	14' - 150#	44.875	28.688	25.625	29.063	16.250
EC-2350-10-S-XX	415	10' - 150#	10' - 150#	44.875	30.688	27.625	31.063	17.250
EC-2350-12-S-XX	428	12' - 150#	12' - 150#	44.875	30.688	27.625	31.063	17.250
EC-2350-14-S-XX	437	14' - 150#	14' - 150#	44.875	30.688	27.625	31.063	17.250
EC-2650-10-S-XX	457	10' - 150#	10' - 150#	44.875	33.688	30.625	33.563	18.250
EC-2650-12-S-XX	470	12' - 150#	12' - 150#	44.875	33.688	30.625	33.563	18.250
EC-2650-14-S-XX	479	14' - 150#	14' - 150#	44.875	33.688	30.625	33.563	18.250
EC-2850-12-S-XX	512	12' - 150#	12' - 150#	44.875	35.688	32.625	35.563	19.250
EC-2850-14-S-XX	522	14' - 150#	14' - 150#	44.875	35.688	32.625	35.563	19.250
EC-2850-16-S-XX	532	16' - 150#	16' - 150#	44.875	35.688	32.625	35.563	19.250
EC-3025-14-S-XX	562	14' - 150#	14' - 150#	44.875	37.438	34.375	37.438	20.250
EC-3025-16-S-XX	572	16' - 150#	16' - 150#	44.875	37.438	34.375	37.438	20.250
EC-3025-18-S-XX	573	18' - 150#	18' - 150#	44.875	37.438	34.375	37.438	20.250
EC-3025-20-S-XX	583	20' - 150#	20' - 150#	44.875	37.438	34.375	37.438	20.250
EC-3350-16-S-XX	713	16' - 150#	16' - 150#	56.750	40.688	37.625	41.063	22.250
EC-3350-18-S-XX	714	18' - 150#	18' - 150#	56.750	40.688	37.625	41.063	22.250
EC-3350-20-S-XX	724	20' - 150#	20' - 150#	56.750	40.688	37.625	41.063	22.250
EC-3550-16-S-XX	759	16' - 150#	16' - 150#	56.750	42.688	39.625	43.063	23.250
EC-3550-18-S-XX	760	18' - 150#	18' - 150#	56.750	42.688	39.625	43.063	23.250
EC-3550-20-S-XX	771	20' - 150#	20' - 150#	56.750	42.688	39.625	43.063	23.250

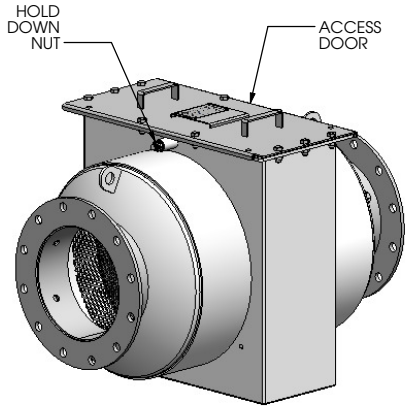
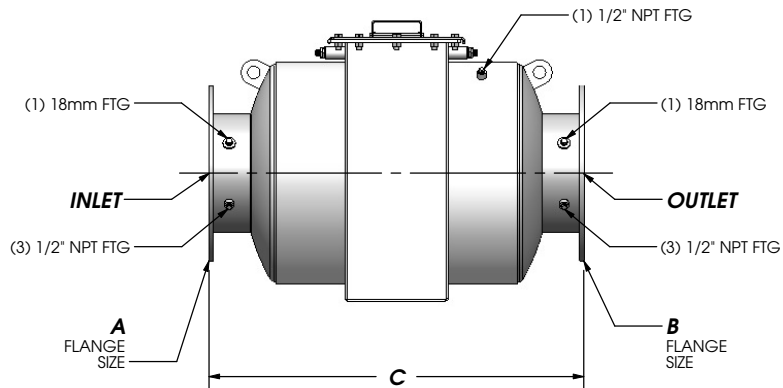

**EC-XXXX-XX-S-XX**

ELEMENT SIZE  
XX.XX

FLANGE SIZE  
XX" 150# FF

MATERIAL CONSTRUCTION  
CS = CARBON STEEL  
SS = STAINLESS STEEL

HOUSING TYPE  
S = HOUSING ONLY

DRAWN	JU	DATE	6/2/2011
ENGINEER	-	DATE	-
APPROVED	-	DATE	-

**PROPRIETARY AND CONFIDENTIAL**

THIS DRAWING CONTAINS PROPRIETARY INFORMATION WHICH IS TO BE HELD CONFIDENTIAL AND MAY NOT BE REPRODUCED OR DISCLOSED TO OTHERS WITHOUT THE PRIOR WRITTEN CONSENT OF EMERACHEM OR A DULY AUTHORIZED REPRESENTATIVE THEREOF.



DRAWING EC-XXXX-XX-S-XX REV 1

**HOUSING SIZING DRAWING**